

18



Europäisches Patentamt
European Patent Office
Office européen des brevets

11 Publication number:

**0 127 483
B1**

12

EUROPEAN PATENT SPECIFICATION

45 Date of publication of patent specification: 11.10.89

51 Int. Cl.⁴: D 04 H 1/54

21 Application number: 84303642.7

22 Date of filing: 30.05.84

54 Elastic thermal bonded non-woven fabric.

30 Priority: 31.05.83 BR 8302903

49 Date of publication of application:
05.12.84 Bulletin 84/49

45 Publication of the grant of the patent:
11.10.89 Bulletin 89/41

84 Designated Contracting States:
AT CH DE FR GB LI SE

68 References cited:
CH-E-mi cal ab
HE-L-ve tic a c
JO-U-m al of
US-A-2 794 750
US-A-4 443 513

73 Proprietor: Johnson & Johnson
501 George Street
New Brunswick, New Jersey 08903 (US)

72 Inventor: Pedro, Gabriel, Jr.
Rua Joao Cursino 222 Apto. 81
Sao Jose Dos Campos Sao Paulo (BR)

74 Representative: Jones, Alan John et al
CARPMAELS & RANSFORD 43 Bloomsbury
Square
London, WC1A 2RA (GB)

EP 0 127 483 B1

Note: Within nine months from the publication of the mention of the grant of the European patent, any person may give notice to the European Patent Office of opposition to the European patent granted. Notice of opposition shall be filed in a written reasoned statement. It shall not be deemed to have been filed until the opposition fee has been paid. (Art. 99(1) European patent convention).

Description

The invention relates to a process for producing an elastic thermal bonded non-woven fabric, and to the fabric that is produced by said process.

5

Background to the Invention

Non-woven fabrics having elastic properties in one direction have enhanced utility for applications such as facing layers for sanitary napkins, diapers, and the like, wherein the elasticity of the fabric provides a "give" in the fabric so that the facing sheet will more readily conform to changes in the shape of the object in response to bodily movement. This invention provides a lightweight, non-woven fabric having elasticity in one direction, and hence the fabric of the invention has enhanced utility for such applications.

Brief Summary of the Invention

The invention provides a process which comprises:

- 15 (a) bonding a web of fusible staple fibers by thermal embossing in an intermittent pattern; and
(b) stretching the bonded web at elevated temperature, to thereby produce a fabric having elastic properties in the direction perpendicular to the direction of the stretch.

20

The Prior Art

Ness, in U.S. Patent No. 3,485,695, discloses a multi-step process for producing a nonwoven fabric having unidirectional elasticity. The steps in the Ness patent are the following:

1. Forming a fibrous web;
2. Rearranging the fibers in the web to form a fibrous web having staggered pores;
25 3. Bonding the web;
4. Drying the bonded web;
5. Drafting the dried, bonded web to elongate said pores;
6. Applying the elastomeric binder to the drafted web; and
7. Drying and setting the elastomeric binder.

30 Ostermeier, in U.S. Patent No. 3,949,128, discloses a nonwoven fabric having bi-directional elasticity. The fabric is composed of spot-bonded continuous and randomly deposited filaments.

Brief Summary of the Drawings

Fig. 1 is a side elevation, partially schematic, of one arrangement of apparatus suitable for carrying out the process of the invention;

Fig. 2 is a top plan view, partially schematic, of another arrangement of apparatus suitable for carrying out the process of the invention;

Fig. 3 shows the embossed pattern for the surface of an embossed calender roll suitable for use in the process of the invention;

Fig. 4 is a cross-section taken along lines 4-4 of Fig. 3;

Fig. 5 shows the pattern of the surface of another embossed calender roll suitable for use in the invention; and

Fig. 6 is a cross-section taken along line 6-6 of Fig. 5.

45

Detailed Description of the Invention

Referring first to Fig. 1, one preferred arrangement of apparatus for carrying out the process of the invention is shown. A web 10 of staple length fusible fibers is fed, as by an endless belt 14, to a calender 12 composed of two rolls 16, 18. The upper roll 16 has an embossed intermittent pattern (which will be described in more detail below), and the lower roll 18 is a smooth back-up roll. Both rolls are heated to a temperature such that the fusible fibers comprising the web 10 are heated to their thermal bonding temperature. Thus, as the web 10 passes through the calender 12, it is thermally bonded in an intermittent pattern corresponding to the embossed pattern of the upper roll 16. The thermally bonded web 20 then proceeds past a set of rolls 22, 23 that are driven at the same circumferential speed as the calendar rolls 16, 18, through an oven 24, and finally to a windup 26. The windup 26 is being driven at a speed such that its circumference is moving faster than the speed of the circumference of the two rolls 16, 18 comprising the calender 12. Therefore, the thermal bonded fabric 20 is stretched in the machine direction as it passes through the oven. Upon cooling, the thus produced fabric 28 will have elastic properties in the cross direction, i.e., the direction transverse to that of the stretch.

Referring now to Fig. 2, an alternate arrangement of apparatus for carrying out the process of the invention is shown. As with the apparatus discussed in connection with Fig. 1, a web 10 of staple length fusible fibers is fed to a calender 12, composed of an embossed roll 16 and a smooth backup roll (not shown). The calender is heated to a temperature such that the fusible fibers comprising the web 10 are heated to their thermal bonding temperature, so that the fabric is thermal bonded in a pattern corresponding to the pattern of the embossed roll 16, which is an intermittent pattern. The thermal bonded web 20 has a width, W1, after having been thermal bonded. The thermal bonded web 20 is then fed to a

65

heated tenter frame 30, wherein the bonded web 20 is heated and stretched in the cross direction as it passes through the tenter frame 30. After passing through the tenter frame 30, the width, W2, of the fabric 32 will be slightly greater than the width, W1 of the fabric 20 as it was fed into the tenter frame 30. The fabric 32, after it cools, will then have elastic properties in the machine direction (i.e., in the direction of the arrow "a"), which is the direction transverse to that to which the fabric was stretched while being heated.

The processes described above are preferred embodiments of the invention wherein the fabric is thermally bonded and then stretched (while being heated) to impart elasticity, in one continuous operation. However, if desired, the fabric may be thermal bonded, collected, and in a subsequent operation, may then be stretched (while being heated) to impart elasticity to the web.

The fibers that are employed in the invention are heat fusible fibers such as polypropylene fibers, highly density polyethylene fibers, polyester fibers, or conjugate fibers having an outer layer of a heat fusible material such as sheath/core polyethylene/propylene fibers having a sheath of polyethylene and a core of polypropylene, and sheath/core polyethylene/polyester fibers having a sheath of polyethylene and a core of polyester. Such heat fusible fibers are commercially available. The fibers that are employed are of staple length, that is, they are usually in excess of about one-half inch in length, up to about three or four inches long. They usually have a denier within the range from about one to about six.

Fibers that are not normally heat-fusible can be used in admixture with the heat-fusible fibers, in minor amounts. Such other fibers include rayon, cotton, wood pulp, and the like.

The feed web 10 employed in the invention is preferably a random web of staple fibers. Random webs are made by known procedures, such as by employing a RANDO WEBBER, or a dual rotor, such as is described by Ruffo and Coyal in U.S. Patent No. 3,768,118. The feed web can weigh, for instance, from about 0.3 to about six ounces per square yard. The exact weight of the feed web has not been found to be narrowly critical.

While the use of random webs is preferred, oriented webs such as card webs can also be used in the invention. When oriented webs are used, in most cases the direction of stretch will be in the direction of fiber orientation (i.e., usually in the machine direction), because the oriented web is usually not strong enough in the direction perpendicular in the orientation to support tension in that (perpendicular) direction.

The thermal bonding of the fibers in the feed web is carried out at an embossed bonder, such as is illustrated in the drawings. The bonder has one roll that has a raised intermittent pattern on its surface, with the other roll being a smooth back-up roll. The temperature at which the thermal bonding is carried out, of course, is dependent upon the nature of the fusible material in the feed web, as well as the weight of the web and the speed of the web through the binder. For instance, at very high speeds, it may be desirable to use a pre-heater in order to heat up the web to close to the bonding temperature just prior to its entrance into the bonder. The bonding temperature of the web is particularly determined by the nature of the material that is thermally bondable. For instance, if the fusible material is high density polyethylene, as it will be in a conjugate fiber having a sheath of high density polyethylene, the bonding temperature is usually within the range of from about 100° to about 150°C. If the fusible material in the web is polypropylene, the bonding temperature is usually from about 130°C to about 190°C. However, the exact bonding temperature is not narrowly critical. The important thing is that the temperature be sufficiently high to soften the fiber so that the pressure from the bonder will cause adhesion of the fusible fibers to one another in a pattern corresponding to the pattern of the embossed roll.

Figs. 3 and 4 illustrate a typical intermittent embossed pattern (a diamond pattern) that is suitable for use in the invention. The exact dimensions of one embodiment of the pattern are given below in the examples. In a preferred way of carrying out the invention, one axis of the diamond pattern is slightly longer than the other axis. In such a case, where the fabric is stretched, it is preferably stretched in the direction of the longer of the two axes.

Other intermittent patterns can also be used in the invention, as is illustrated by the embossed pattern shown in Figs. 5 and 6. The only requirement is that there be alternating areas of bonded and unbonded fibers. Thus, overall bonded thermal bonded fabrics cannot be used in the invention.

The pressure on the calender bonder has not been found to be narrowly critical. It will normally be within the range of from about 18 to about 850 pound per linear inch.

After having been thermal bonded, the bonded fabric is then subjected to a stretch while being heated. A stretching of from about 5% up to perhaps 40% or 50% is feasible, although a stretching of from about 15% to about 30% is preferred. As was discussed above, the stretching can either be in the machine direction, which is more readily carried out because the equipment therefor is less expensive, or it can be in cross direction if one employs a heated tenter frame to do the stretching. While the fabric is being stretched, it is also subjected to elevated temperature, of from, for example, about 100° to about 160°C.

The exact temperature to which the fabric is heated while being stretched depends upon the nature of the fusible fiber in the fabric, since the temperature should be about the softening point of the fiber.

The examples below illustrated the practice of the invention.

Example 1

A random laid web of staple fibers was employed in this example. The web was composed of 75 weight per cent of 3 denier polypropylene fibers having a staple length of one and one-half inches, and 25 weight per cent of 1.5 denier polyester fibers having a staple length of one and one-half inches. The total

EP 0 127 483 B1

base web weight was 60 grams per square meter, or 1.77 ounces per square yard. This web was subjected to thermal emboss bonding using an emboss bonder having a raised emboss pattern as shown in Figs. 3 and 4. The raised emboss lines 40 were in a diamond pattern, with the dimensions "A" being 5.5 millimeters, the dimensions "B" being 0.8 millimeter, and the dimension "C" being 0.035 millimeter. The angles "D" were 30°C.

In Example 1, the long axis of the diamond was oriented in the cross direction. The above-described web was fed through the emboss bonder, which was heated to a temperature of 165°C. The pressure on the web as it passed through the emboss bonder was 270 pounds per linear inch.

After having been thermally emboss bonded, the web was passed through a heated tenter frame where it was stretched to a final width, W2, that was 125% of the unstretched width, W1 (See Fig. 2). The tenter frame was maintained at a temperature of 140°C.

The properties of the resulting fabric, both before stretching and after stretching, are displayed below in Table I:

TABLE I

	Before Stretching	After Stretching	Variation
Weight, oz/yard ²	1.77	2.21	+25%
Tensile strength, CD, pounds per inch, 12 ply	39.5	62.1	+57%
Tensile strength, MD, pounds per inch, 12 ply	15.5	11.65	-25%
CD elongation before breaking, per cent	19.2	9.6	-50%
MD elongation before breaking, per cent	16.8	74.4	340%

Example 2

In this example, a web similar to that employed in Example 1 was used, except that it had basic weight of 25 grams per square meter (0.74 ounces per square yard). In this example, the emboss pattern was the same as that used in Example 1, except that the long axis of the diamond pattern was oriented in the machine direction.

The web was fed through the emboss bonder at a speed of 10 yards per minute, with the emboss bonder being maintained at a temperature of 160°C. The pressure on the web going through the bonder was 360 pounds per linear inch. In this example, the windup batcher was run at a speed of 12.5 yards per minute, which is 125 per cent of the speed of the web that was fed into the emboss bonder. In between the emboss bonder and the batcher, there was an oven, in which the web was heated to a temperature of 140°C.

The properties of the fabric so produced are shown in Table II:

TABLE II

	Before Stretching	After Stretching	Variation
Weight (oz per square yard)	0.67	1.06	+44%
Tensile strength, CD, pounds/inch, 12 ply	12.94	6.73	-48%
Tensile strength, MD, pounds/inch, 12 ply	27.19	41.4	+52%
CD elongation before breaking, per cent	37.2	91.2	-145%
MD elongation before breaking, per cent	14.4	7.2	-50%

In Examples 1 and 2, the increased elasticity in the direction transverse to which the web was stretched is shown in the markedly increased elongation in that direction. The fabrics produced by this invention have enhanced utility as facing fabrics for articles such as sanitary napkins, disposable diapers, bandages, and the like, in which a degree of stretch in one direction is useful in order to help permit the article having the fabric as a facing fabric to conform more readily to bodily movement.

EP 0 127 483 B1

Example 3

The procedure of Example 2 was repeated, except that the 75% polypropylene/25% polyester fibrous feed web was a carded web weighing 0.67 ounces per square yard.

The web was fed through the emboss bonder at a speed of 10 yards per minute with the emboss bonder being maintained at a temperature of 150°C. The pressure on the web going through the bonder was 200 pounds per linear inch. In this example, the windup batcher was run at a speed of 13 yards per minute, which is 130 per cent of the speed of the web that was fed into the emboss bonder. In between the emboss bonder and the batcher, there was an oven, in which the web was heated to a temperature of 120°C.

The properties of the fabric so produced are shown in Table III:

TABLE III

	Before Stretching	After Stretching	Variation
Weight (oz per square yard)	0.67	1.41	+110%
Tensile strength, CD, pounds/inch, 12 ply	2.65	2.2	-17%
Tensile strength, MD, pounds/inch, 12 ply	43.65	72.7	-67%
CD elongation before breaking, per cent	50.4	135.6	+169%
MD elongation before breaking, per cent	8.4	6	-29%

Example 4

The procedure of Example 2 as repeated, except that the 75% polypropylene/25% polyester feed web was a random web weighing 0.67 ounces per square yard, and the calender employed a roll that was embossed in the dash pattern shown in Figs. 5 and 6, wherein the axis "y" was oriented in the machine direction, and the several dimensions were the following:

- g = 0.5 millimeter (0.02 inch)
- p = 1 millimeter (0.04 inch)
- q = 5 millimeters (0.2 inch)
- r = 2 millimeters (0.08 inch)
- s = 3 millimeters (0.12 inch)

The web was fed through the bonder at a speed of 12 yards per minute, with the bonder being maintained at a temperature of 150°C. The pressure on the web going through the bonder was 200 pounds per linear inch. In this example, the windup batcher was run at a speed of 15 yards per minute, which is 125 per cent of the speed of the web that was fed into the bonder. In between the bonder and the batcher, there was an oven, in which the web was heated to a temperature of 130°C.

The properties of the fabric so produced are shown in Table IV:

TABLE IV

	Before Stretching	After Stretching	Variation
Weight (oz per square yard)	0.67	1.39	+107%
Tensile strength, CD, pounds/inch, 12 ply	11.9	6.6	-45%
Tensile strength, MD, pounds/inch, 12 ply	18.52	29.76	+60%
CD elongation before breaking, per cent	25.2	87.6	+247%
MD elongation before breaking, per cent	15.6	7.2	-54%

Claims

1. Process which comprises stretching, at elevated temperature, a thermally bonded web wherein the thermal bonds are in an intermittent pattern, and then cooling the stretched web, to thereby produce a

fabric having elastic properties in the direction perpendicular to the direction of stretch.

2. Process which comprises the steps of:

- (a) bonding a web of fusible staple fibres by thermal bonding in an intermittent pattern;
- (b) stretching the bonded web at elevated temperature; and

5 (c) cooling the stretched web,

to thereby produce a fabric having elastic properties in the direction perpendicular to the direction of stretch.

3. The process of claim 1 to claim 2 wherein said web of fusible staple fibers is a random web.

4. The process of any of claims 1 to 3 wherein said intermittent pattern is a diamond pattern.

10 5. The process of any of claims 1 to 3 wherein said intermittent pattern is a dash pattern.

6. The process of any of claims 1 to 5 wherein the fusible fibers are polypropylene, polyethylene, polypropylene/polyethylene conjugate fibers, or polyester/polyethylene conjugate fibers.

Patentansprüche

15

1. Verfahren, welches das Verstrecken einer thermisch gebundenen Bahn, in welcher die thermischen Bindungen in einem intermittierenden Muster vorliegen, bei erhöhter Temperatur und das anschließende Kühlen der verstreckten Bahn umfaßt, um dadurch einen Stoff mit elastischen Eigenschaften in derjenigen Richtung, die zu der Richtung des Verstreckens senkrecht verläuft, zu erzeugen.

20

2. Verfahren, welches die folgenden Schritte umfaßt:

(a) Binden einer Bahn aus schmelzbaren Stapelfasern durch thermisches Binden in einem intermittierenden Muster;

(b) Verstrecken der gebundenen Bahn bei erhöhter Temperatur und

25

(c) Kühlen der verstreckten Bahn, um dadurch einen Stoff mit elastischen Eigenschaften in derjenigen Richtung, die zu der Richtung des Verstreckens senkrecht verläuft, zu erzeugen.

3. Verfahren nach Anspruch 1 oder Anspruch 2, wobei die Bahn aus schmelzbaren Stapelfasern eine nicht orientierte Bahn ist.

4. Verfahren nach einem der Ansprüche 1 bis 3, wobei das intermittierende Muster ein Rhombenmuster ist.

30

5. Verfahren nach einem der Ansprüche 1 bis 3, wobei das intermittierende Muster ein Strichmuster ist.

6. Verfahren nach einem der Ansprüche 1 bis 5, wobei die schmelzbaren Fasern Polypropylen- oder Polyethylenfasern oder Polypropylen/Polyethylen-Konjugatfasern oder Polyester/Polyethylen-Konjugatfasern sind.

35

Revendications

1. Procédé qui consiste à étirer à une température élevée une bande thermiquement liée dans laquelle les liaisons thermiques sont en un motif intermittent et, ensuite à refroidir la bande étirée pour produire ainsi une étoffe possédant des propriétés élastiques dans le sens perpendiculaire à celui de l'étirage.

40

2. Procédé qui consiste:

(a) à lier une bande en fibres discontinues fusibles par liaison thermique en un motif intermittent;

(b) à étirer la bande liée à une température élevée; et

45

(c) à refroidir la bande étirée pour ainsi produire une étoffe possédant des propriétés élastiques dans le sens perpendiculaire à celui de l'étirage.

3. Procédé selon la revendication 1 ou 2, dans lequel ladite bande de fibres fusibles discontinues est une bande statistique.

4. Procédé selon l'une quelconque des revendications 1 à 3, dans lequel ledit motif intermittent est un motif en losange.

50

5. Procédé selon l'une quelconque des revendications 1 à 3, dans lequel ledit motif intermittent est un motif en tirets.

6. Procédé selon l'une quelconque des revendications 1 à 5, dans lequel les fibres fusibles sont en polypropylène, polyéthylène, des fibres conjuguées polypropylène/polyéthylène ou des fibres conjuguées polyester/polyéthylène.

55

60

65

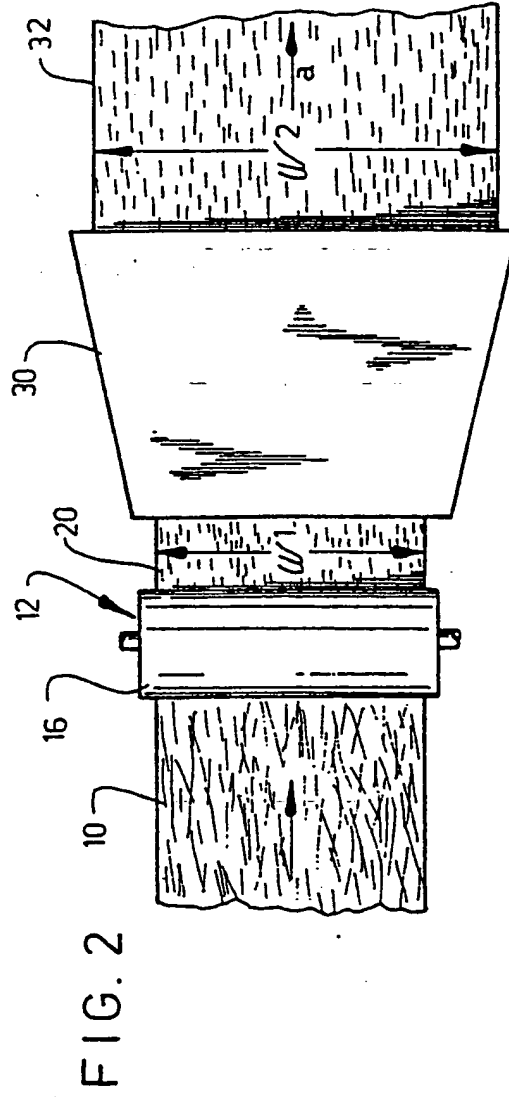
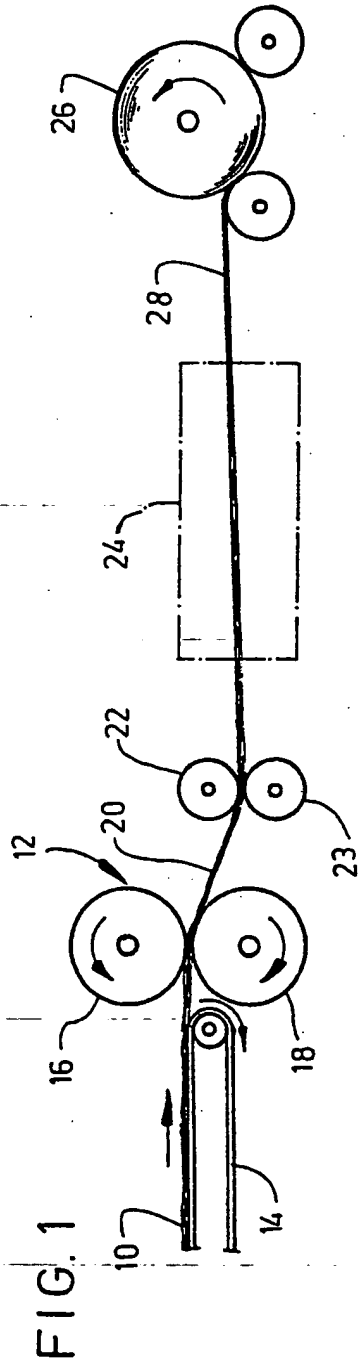

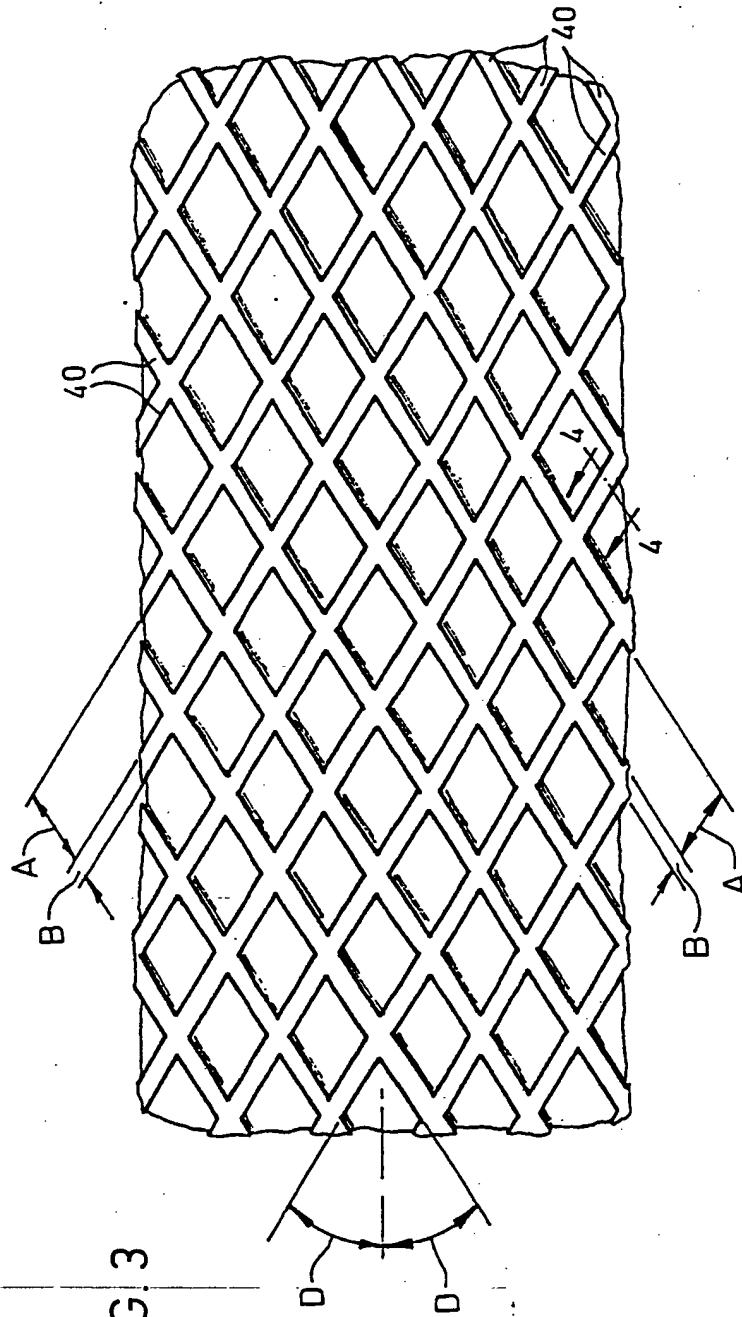

FIG. 3

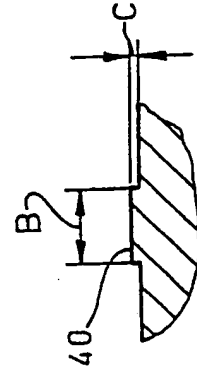

FIG. 4

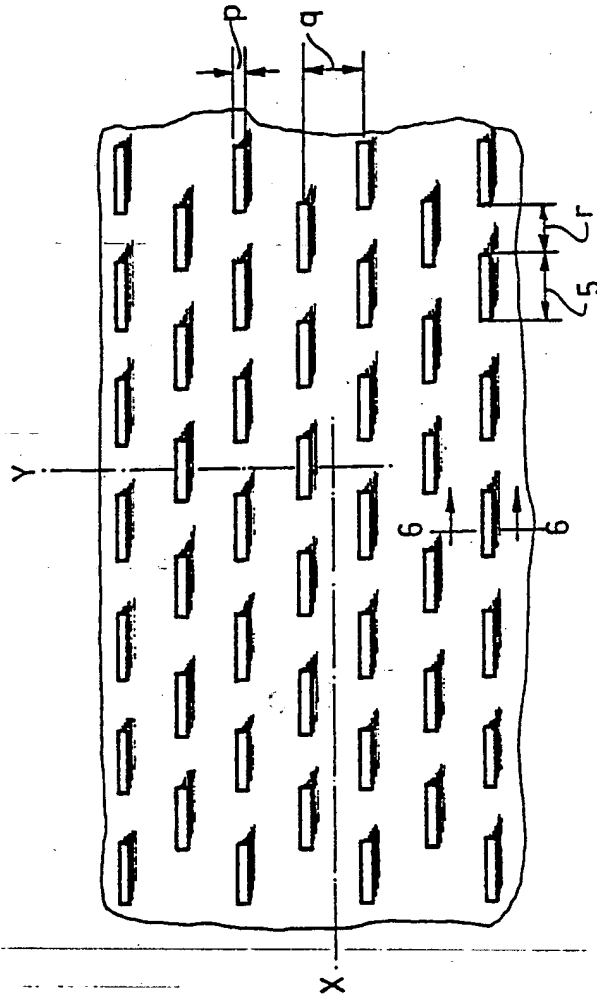

FIG. 5

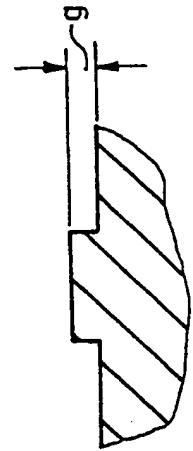

FIG. 6

THIS PAGE BLANK (USPTO)